

Payphone Contour 300 Plus
User guide

Calls and cash pages 4 – 9

find out:

- ▶ how to make calls
- ▶ about the different types of calls you can make
- ▶ how to check your cash

calls

making a call	4
making calls without using coins	4
calling a memory number	5
changing the speech volume	5

more call functions

making another call	6
redialling the last number	7

ring volume

changing the ring volume	8
--------------------------------	---

cash

checking your takings	9
emptying the cash tray	9

Features pages 10 – 19

find out how to get the most from your payphone

If you'd like to change the way any of these features work, you can contact us using the details on page 23, or follow the instructions in this section.

Subject to your contract with BT Payphones, you may not be able to change some of these features.

PIN change	12	old coins	16
call barring	12	new coins	16
call back	12	call privacy	17
call charges	13	caller display	17
minimum fee	13	time	18
memory buttons	14	day	18
reverse charge calls	14	dialing types	18
new call types	15	barring operator calls	18
display languages	15	incoming call barring	19
fake coins	16	switchboard settings	19

Troubleshooting pages 20 – 21

how to solve some of the more common problems

Technical page 22

Making calls and managing your cash

Making a call

- 1 Lift the handset and insert your money

eg

- 2 Dial the number

When you've dialled, the payphone will check that there's enough money to start the call. If there isn't, it will eject the first coin and request one of a higher value.

eg

You can check how many seconds you'll get for 10p or the minimum fee for this call. Check your notice for details.

- 3 Watch the display for information

The display shows how much is left during the call. When 20 seconds of call time is left, you'll hear the pips. If you don't add any coins, the call will end. Remember the payphone doesn't return unused coins.

You can make calls without using coins

Only people with the PIN can do this.

- 1 Lift the handset and press *

- 2 Enter your PIN

eg

- 3 Press NEXT CALL

- 4 Dial the number

eg

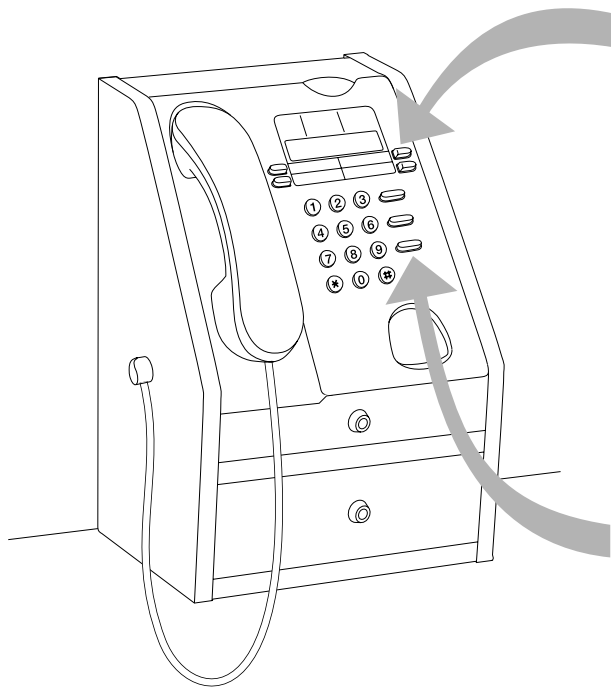

Calling a memory number

- 1 Lift the handset and insert your money

INSERT 20P

- 2 Press the memory button and wait for the call to be answered

Any more coins you put in while the payphone is dialling will be ejected.

eg TAXI

Changing the speech volume

Press **VOLUME** once to increase the volume

Press **VOLUME** again to return to the initial volume



The Contour 300 Plus is fitted with an inductive coupler handset that makes calls easier to hear when used with a suitable hearing aid.

If you use a behind-the-ear hearing aid, move the switch to the 'T' position and hold the handset earpiece next to the hearing aid.



Making another call

1 Don't hang up at the end of the first call
*As long as you have the minimum fee left,
you can make another call.*

2 Press **NEXT CALL**

PLEASE DIAL

3 Dial the next number you want

eg 020 7123 456

4 Watch the display for information

Redialling the last number you called

1 Don't hang up when you hear the engaged tone

2 Press **NEXT CALL**

PLEASE DIAL

3 Press **REDIAL**

The payphone will redial the last number for you

eg 020 7123 456

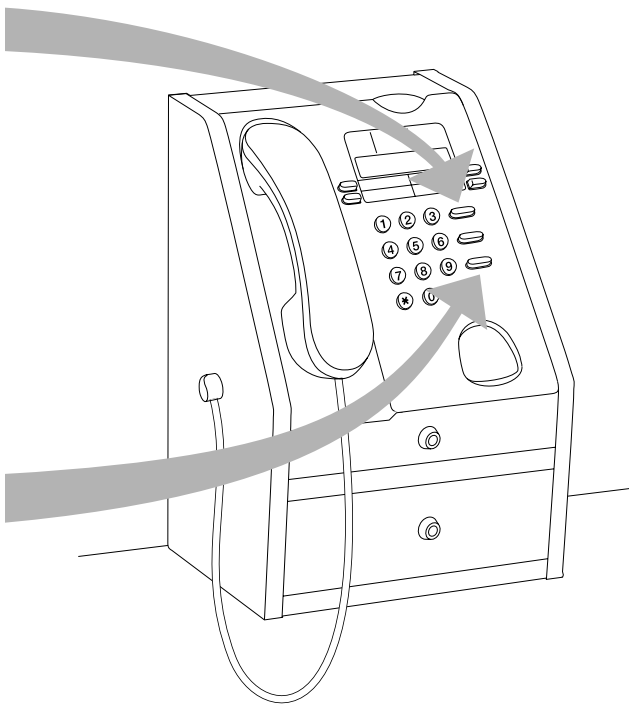

Changing the ring volume

You can change the volume your payphone rings at to make sure you hear it when someone calls. You can set the ring volume to high, low, or even switch it off altogether.

We can do this for you if you contact the Helpdesk. For contact details, see page 23.

- 1 Unlock the top cover and remove it
 - 2 Switch the ringer to the volume you want.
-

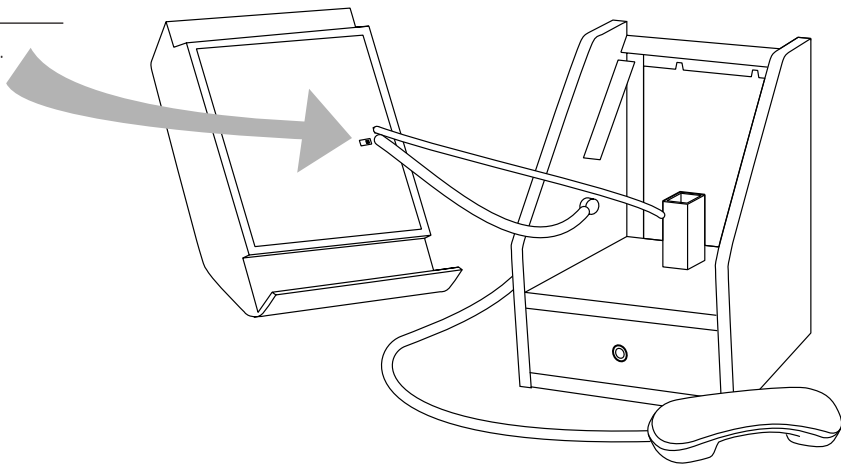
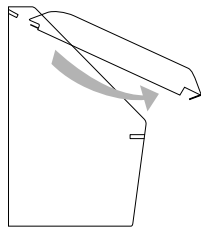
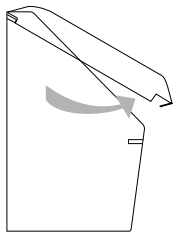

Checking your takings

- 1 Lift the handset and unlock the cover

PIN

- 2 Press ***66#**

The display shows how much money the payphone has taken since it was last reset. If you're going to empty the cash tray, reset the payphone to £0.

- ▶ To leave the amount unchanged

Press **#**

eg £32.40

- ▶ To reset to £0

Press **0#**

£0.00

- ▶ To see how much the payphone has taken since it was first used

Press **#** again.

eg £145.76

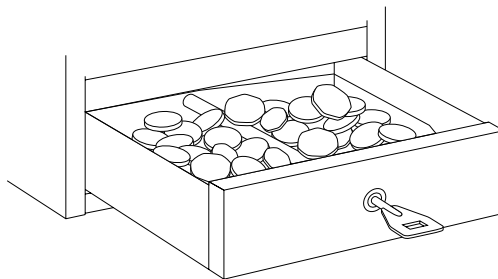

Emptying the cash tray

Unlock and remove the tray.

After you've emptied the cash tray, make sure that you replace and lock it.

Features

Your Contour 300 Plus's many features let you choose just how you want it to work.

Contact the Helpdesk if you'd like to change the way the features work. We can do this as soon as you call.

We'll need to know the telephone number of your payphone, and we may also ask you some security questions.

For contact details, see page 23.

You can programme the features yourself if you want to. The rest of this section tells you how

Programming the features yourself

Before you can programme the features you need to begin the owner programming mode

-
- 1 Lift the handset 
 - 2 Unlock the top cover 
 - 3 Enter your PIN 
 - 4 Press # 

Now you're ready to choose the feature you want to programme.

Feature	page
Use the PIN change feature if you think someone else knows your PIN or you want one that's easier to remember	12
Use Call barring to stop calls to certain numbers	12
Stop the last person called from making a Call back to your phone so that other people who are waiting have chance to make their call	12
Alter the Call charges to give callers more or less time for their money	13
You can change the Minimum fee if most calls from your payphone are short	13
Programme the Memory buttons with useful phone numbers	14
You can avoid accepting Reverse charge calls so that you don't have to pay for them	14
Programme New call types if you want to charge a specific fee for certain types of calls	15
If you get a lot of people from overseas using your payphone, you can let them choose their Display language	15

Feature	page
Programme your payphone to recognise New coins when they're introduced and to reject Fake or Old coins	16
Switch on Call privacy if you've got more than one phone connected to your line	17
Stop your phone number from being available to people with Caller display	17

Extra features

Set the Time and Day so that your payphone can work out what rate to charge for calls	18
If you're on an older exchange, you might need to switch the Dialling type from tone to pulse dialling	18
You can bar Incoming operator calls to stop them connecting reverse charge calls to your payphone	18
As your payphone doesn't charge for incoming calls, you can use Incoming call barring to bar them	19
Make Switchboard settings if your payphone is on a switchboard and you need to dial a number to get an outside line	19

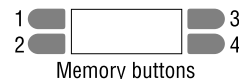
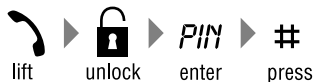
Begin

Choose the feature to programme → Start → Programme ... → ... and watch the display → End

PIN change

Change your PIN if you think that someone else has found out what it is or if you want one that's easier to remember.

*74# Enter the PIN you want SET TO _ _ _ #

Keeping your PIN Safe

If you want to write your PIN down, make sure you disguise it as another number such as phone number or birthday.

Barring calls

You can stop calls from being made to certain types of numbers, such as international numbers.

*22# Press **Memory 1** to choose the type of call you want to bar
Press **Memory 3** to change between barred ✗ and allowed ✓ FREE #

Call back

You can stop people from calling the payphone back. This is useful for making sure that it isn't always busy with people who aren't paying for their calls.

*56# Press **Memory 3** to choose whether to allow people to call the payphone back ✓ or not ✗ LAST NO #

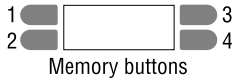

Finish



Choose the feature to programme

Start

Programme ...

... and watch the display

End

Call charges

You can decide how much to charge for calls by changing the number of seconds callers get for 10p on all the different types of call.

The higher the charge rate the higher the call charge.

Contour 300 Plus calculates the cost of each call made internally and does not require meter pulses generated by the exchange.

***24#**

Press **Memory 3** to increase charge rate
Press **Memory 4** to decrease the rate

CHARGE 100

#

*Your payphone is first set to charge rate 100.
You can choose any rate between 20 and 500.*

How charge rates work: If callers get 60 seconds for 10p at charge rate 100, doubling the charge rate to 200 halves the number of seconds to 30 for 10p.

Minimum fee

You can change the minimum fee for a call – useful if most calls from your payphone are short.

***64#**

Press **Memory 3** to increase the fee in 10p steps
Press **Memory 4** to decrease the fee in 10p steps

20P

#

The highest setting is £1

Begin

lift



unlock

PIN

enter

#

press

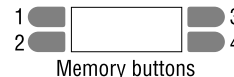

Memory buttons

Choose the feature to programme

Start

Programme ...

... and watch the display

End

Memory buttons

You can programme up to four numbers which can be dialled by just pressing the memory buttons.

You can choose a fixed fee for memory buttons so that all calls to that number are charged a set amount of your choice.

If you would like us to programme names for your memory buttons, such as TAXI, contact the Helpdesk. For contact details, see page 23.

*63#

- ▶ Dial the phone number
 - ▶ Press **Memory button** for that number
 - ▶ Press **Memory 2** to choose the type of call, such as fixed fee.
- If you choose a fixed fee, press # and then use Memory 3 to set the fee.*
- ▶ Repeat to programme the next memory button

ENTER TEL

#

FREE

ENTER TEL

Clearing a memory button

- ▶ Press **REDIAL** when the display says...
- ▶ Press the **Memory button** you want to clear

Reverse charge calls

BT operators can tell that your phone is a payphone, and that they shouldn't connect reverse charge calls to it, from the brief tones it makes at the start of calls.

You can switch this tone off but we recommend that you leave it on.

*43#

- ▶ Press **Memory 3** or **4** to switch the payphone ID on ✓ or off ✗

ID TONE

#

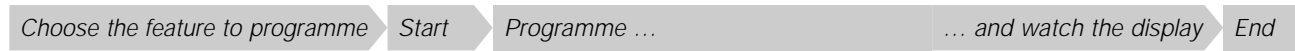
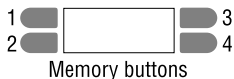

New call types

When you dial a phone number, the payphone looks at the number and decides what rate to charge for that call.

You can alter the call type for numbers so that you charge a different rate or you can even set a fixed fee.

For instance, you could set a certain rate for international calls. You can also bar calls to numbers that start with certain codes.

- ▶ ***39#** If you've already programmed some call types, press **Memory 3** until the display shows -----
 - ▶ Enter the number
 - ▶ Press **#**
 - ▶ Press **#** to bar the number, or press **Memory 1** to choose the charge rate



Cancelling a call type

Follow the instructions above and press **REDIAL** when the display shows the code you want to cancel

Display languages

You can let callers choose whether to see the display messages in English, French, German, Welsh, Spanish or Italian.

- ▶ ***52#** Press **Memory 3** to switch the languages on ✓ or off ✗
 - ▶ Lift the top cover and push the lever to release the display cover.
 - ▶ Turn the card around to show the flag symbols.



Begin

lift



unlock

PIN

enter

#

press

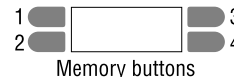

Memory buttons

Choose the feature to programme

Start

Programme ...

... and watch the display

End

Fake coins

You can stop fake coins or tokens – called slugs – from being used to make calls.

*86#

- ▶ Press ##
- ▶ Insert 8 of the tokens or coins

SLUG

#

Old coins

You can stop coins that go out of circulation from being used to make calls.

*26#

- ▶ Press **Memory 1** to select the coin you want to stop
- ▶ Press **Memory 3** to stop it from being used for calls

COIN TOP

COIN TOP X

#

New coins

You can programme your payphone to recognise new tokens and coins. The payphone will be better at recognising the new token or coin if you use eight different ones to programme it.

You can programme up to two tokens or coins.

*86#

- ▶ Insert eight of the tokens or coins
- ▶ Press **Memory 3** or use the keypad to set the value of the coin

TOKEN A1

#

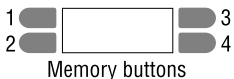

Finish



Choose the feature to programme

Start

Programme ...

... and watch the display

End

Call privacy

If you have other phones connected to the same line as your payphone, the payphone could be used to listen in to your extensions.

You can stop people using your payphone to listen in to calls made on your extension by switching the privacy feature on.

If call privacy is on, you will not be able to transfer calls from your extension to your payphone.

*77#

▶ Press **Memory 3** to switch the privacy feature on ✓ or off ✗

PRIVATE

#

Caller display

You can display the phone numbers of people who call your payphone.

*36#

▶ Press **Memory 3** to switch Caller display on ✓ or off ✗

DISPLAY

#

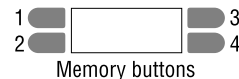
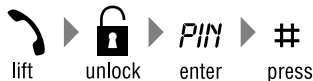
Begin

Choose the feature to programme → Start → Programme ... → ... and watch the display → End

Time

The time and day are used to work out what rate to charge for calls.

***84#**

Press **Memory 3** to move time forward
Press **Memory 4** to move time back

TIME 14:26

#

Day

The time and day are used to work out what rate to charge for calls.

***32#**

Press **Memory 3** to move day forward
Press **Memory 4** to move day back

TUESDAY

#

Dialling types

Most phone exchanges use Touchtone™ dialling which makes musical notes as you dial. If you can't get through, try switching to pulse dialling.

***34#**

Press **Memory 3** to change between tone and pulse

TONE

#

Operator calls

You can bar incoming operator calls to stop them connecting reverse charge calls.

***67#**

Press **Memory 3** or **4** to bar or unbar operator calls

#

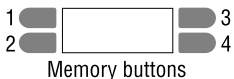

Incoming calls

You can stop your payphone from answering incoming calls.

***46#** Press **Memory 3** or **4** to change between answer ✓ and answer ✗ **#**

Switchboards

There are two ways to use your payphone on a switchboard where you need to dial an access number such as 9 to get an outside line:

Automatic access code

The payphone dials the access number automatically but you won't be able to make internal calls using the payphone.

***72#** **Automatic access code** **#**

- ▶ Enter the code for an outside line
- ▶ Press **#**
- ▶ Press **#**
- ▶ Press **Memory 3** or **4** increase or decrease the time the payphone waits to get an outside line before dialling

*AUTOMATIC
PAUSE 3-5*

User keyed access code

Callers have to dial the access number before they can make an external call. You'll be able to use the payphone for internal calls.

User keyed access code

- ▶ Enter the code for an outside line
- ▶ Press **#**
- ▶ Press **Memory 1**
- ▶ Press **#**
- ▶ Enter the first digit of your extension phone numbers

*AUTOMATIC
USER KEYED
EXTENSION*

If you have any problems, please contact the Helpdesk. For contact details, see page 23.

Canceling a code

Follow the instructions above and press **REDIAL** when the display shows the code you want to cancel

Troubleshooting

Problem	Solutions
<i>No dialling tone</i>	<ul style="list-style-type: none"> ▶ Check that the payphone is plugged into the phone socket. ▶ Contact the Helpdesk for contact details, see page 23
<i>Continuous dialling tone after you dial</i>	<ul style="list-style-type: none"> ▶ Change dialling type, try again ▶ Contact the Helpdesk for contact details, see page 23
<i>Display is blank</i>	<ul style="list-style-type: none"> ▶ Check that the payphone is plugged into the phone socket. ▶ Contact the Helpdesk for contact details, see page 23
<i>Line is busy</i>	<ul style="list-style-type: none"> ▶ Check that the payphone is plugged into the phone socket. ▶ Contact the Helpdesk for contact details, see page 23

Problem	Solutions
<i>Display says EMERGENCY CALLS ONLY</i>	<ul style="list-style-type: none"> ▶ Check the cash box is not full. ▶ Check that the coin slot is not jammed.
<i>Coins not accepted</i>	<ul style="list-style-type: none"> ▶ Check the cash box is not full. ▶ Check that the coin slot is not jammed.
<i>Lost keys</i>	<ul style="list-style-type: none"> ▶ Call the Helpdesk on Freefone 0800 373 085. If you know your key numbers, please have them ready.
<i>Unknown PIN</i>	<ul style="list-style-type: none"> ▶ Contact the Helpdesk for contact details, see page 23
<i>Display says PIN</i>	<ul style="list-style-type: none"> ▶ Check that the top cover is locked and the key is not in the lock.

Problem	Solutions
<i>No ring</i>	<ul style="list-style-type: none">▶ Check that the ring switch is on.▶ Check that incoming calls are not barred – see page 12.▶ Check that you don't have too many phones connected to your payphone line. <p><i>Your Contour 300 Plus has a REN of 2, check that the total REN of all your phones doesn't add up to more than 4.</i></p> <p><i>Each phone connected to a phone line uses the signal that comes down the line. The signal is only strong enough for a few phones so you need to make sure you don't have too many phones connected to the line. The REN number is a guide to how much of the signal your phone uses.</i></p>

Technical

Protecting against vandalism and theft

Your Payphone Contour 300 Plus is designed for use in constantly supervised and sheltered sites. It is not recommended for locations where there is any risk of vandalism or theft.

Connecting to the BT Network

The Payphone Contour 300 Plus is approved:

- to provide a public payphone service
- for multi-frequency (tone) and loop disconnect (pulse) dialling
- for inductive coupling to appropriate hearing aids
- for Call barring
- for use with compatible:
 - PBXs
 - PABXs
 - key systems
 - dealerboards
 - key and lamp units
 - automatic call distributors which provide a BS6312 compatible port and meet the requirements for simple phones. Your supplier will be able to provide you with a list of compatible apparatus.

Maintaining your Payphone Contour 300 Plus

Keep the Payphone clean and make sure that the coin slots are always free of obstructions.

Do not polish the keypad.

Requirements for payphone notices

OFTEL Regulations require you to display a payphone notice which gives the following information:

- details of limitations of access to the 100 operator service
- what happens to unused coins
- the minimum payment to make a call
- the method of payment
- the full postal address of the location of the payphone
- the person who should be contacted about caller complaints
- how calls are charged
- an indication that 999 and 112 calls are free
- a warning that calls may be overheard where other extensions are connected to the same line.

VAT liability

If you are registered for VAT, you will be required by HM Customs and Excise to account for the VAT on the cash you collect in your Payphone Contour 300 Plus.

Liability for calls

You must pay all the BT call charges. Calls are charged at standard BT rates.

You can set the rate that you charge for calls made from your Payphone Contour 300 Plus.

You might want to use the money you collect to contribute to the call charges and rental charges.

BT Chargecard calls

Calls made with a BT Chargecard which is charged to your Payphone Contour 300 Plus's phone number will be charged on your phone bill in the normal way. You will not be charged for calls made with other BT Chargecards.

Important information

Make a note of your **BT Contour 300 plus Payphone** serial number which is printed on the bottom of your phone

Your cash box key number

If you need any help, please visit our website at www.bt.com/payphones

If you need to contact us, please send an email with your query to product.help.payphones@bt.com or call the **Payphone Helpdesk** free on **0800 25 25 41** and we will be pleased to help you. Lines are open Monday to Saturday, 8am to 6pm.

If you require replacement keys contact **X2Connect Ltd on 0800373085**

If you would like to speak to our Sales Team, please call the **Payphone Sales Desk** free on **0800 11 55 11**. Lines are open Monday to Friday, 8am to 6pm and Saturday from 9am to 2pm.