

# Robust web phone and kiosk solutions creating revenue and service opportunities

The X2Connect NET800 Web phone Interactive Kiosk Range.



X2Connect's NET800 web phone is a flexible solution for interactive applications. This platform is designed to maximise revenue and optimise service provision in street, public and private market sectors.

### Flexible and User Friendly

The X2Connect NET800 product range is a world leading solution for a host of locations, particularly street and other environments that need either a high range of weather or vandal protection. Products can be booth or wall mounted and offer hardware configuration options. The 12.1-inch (307mm) display with touchscreen is the primary user interface. Graphical menus and content applications are open to custom design and development. For commerce and payment, The X2Connect NET800 accepts coins and cards. If printers are needed, then X2Connect offers a range of partner solutions.

### Consumer Interaction and Business Services

The X2Connect NET800 promotes on-line services and revenues for payphone and kiosk operators or those interested in enhancing their points of presence or service offering; such as government agencies, banks, telecom operators, retailers and kiosk service providers; whether it be: -

- To increase sales throughput
- Capture attention and connect users with interactive applications
- Enhance access to services and information.
- Raise your public profile.

X2Connect has the track record, experience, solutions, capabilities, the products and the technologies to work with clients to develop and integrate solutions for each of these important requirements.

### Designed for Now and the Future

X2Connect has drawn on considerable experience to develop the NET800 Web phone range, resulting in this class-leading product. Enhanced street payphone technologies such as anti-theft and anti-vandal design features deter physical attacks. Robust software counters fraud and malicious 'hackers' for secure operation. The NET800 offers as options picture, video and text email, Internet access, SMS and MMS messaging services as well as a range of on line media including broadband video streaming, games, and content retailing.

Sponsored content channels and advertising provide third party revenue opportunities as well. Broadband connections enable terminals to pull down on-line and server content for immediate delivery or local storage.

With wireless connectivity interfaces, the NET800 can provide a media and data portal to portable consumer devices, such as the latest mobile phones, laptop computers and electronic organisers.

### Terminals

- Street
- Retail
- Government
- Leisure
- Telecommunications
- Customer Service

### Services

- Hardware Supply
- System Resilience and Operating Systems
- Application Provision
- Management Systems
- Full System and Services Integration

# Discover how these best in class terminals and communications technologies can release value to your customers and ensure that you stay ahead of your competitors.



## Telecommunications

Public and private payphone operators as well as new entrants now have a tool to enhance their services and generate new revenues. New communication and information services can be delivered via robust and friendly platforms providing an internet service for everybody, enabling e-commerce transactions and interactive advertising.

The flexible family of interactive terminals from X2Connect takes provision of telecommunications services into the future. With a robust web phone for outdoor locations and a range of highly configurable kiosk variants for indoor locations, you have a solution for revolutionising your network access points.

Not only can units accept payment to access Internet, e-mail, SMS and MMS services, they can also integrate WiLAN modules and related access control software. At low cost you can economically deploy public WiLAN, using the X2Connect NET800 as the hub and promotional device. The NET800 can be configured as a highly visible wireless broadband network or retail access point.

## Government Information Portals

Public access to government services is increasingly a key driver for interactive terminal deployments. X2Connect has experience of delivering digital divide or public/private partnerships in a range of forms. Let X2Connect help you transform the way you deal with and reach citizens and provide interactive services, introducing or enhancing access for everyone to important or local national services.

## Leisure and Entertainment

With more leisure-time available than ever before, consumers expect a high level of service combined with flexibility and convenience. X2Connect Interactive web phone and kiosks can achieve all of this, as well as providing an engaging platform for all of your customers.

Because interactive terminals are a proven way of engaging consumers and encouraging them to actively interact, they can try before they buy with music or movie previews, select cinema seats, book sports facilities or even play on line games or quizzes.

X2Connect's solutions allow content and media retailing to mobile phones and Personal Digital Assistants (PDA). This new service allows multimedia to be vended and digitally transferred over GPRS to mobile phones. X2Connect's services include polyphonic and monophonic ring tones, still and animated wallpapers and greeting cards, postcards and also Java games.

## Our Services, Our Solution

It's not just the hardware and software that X2Connect can provide, A full consultation service for operation, service, usability and deployment is available. X2Connect has unbeatable experience through the range of its deployments and the products to match. Whichever applications you need, X2Connect interactive terminals can provide customers with quick and easy access to specific content and media applications. Our attractive pricing, pedigree and value added services allow you to formulate a competitive strategy that will see you enhance services and revenues and stay ahead of the competition.

X2Connect recognises that central management systems and servers are the key to successful and cost effective deployments. Please refer to our NETms Enterprise Kiosk Datasheets for further details of our integrated offerings.



## Flexibility of installation

The NET800 product is designed to provide an extremely compact form and is designed to fit within traditional payphone booths or to be wall mounted.

Specifically, options such as handset, coin, card and keypad elements can be deselected if a simple point of information is required,

The X2Connect software applications facilitate simple on site configuration using an attractive, interactive and simple to use GUI.

## Strength of design & build

The products are designed to be resistant to a range of weather and environmental conditions expected with outdoor use. An attractive range of services and peripherals (hardware and software features) provide a superb set of offerings across the diverse range of web phone needs and ensure system reliability within these tough environments.

## Attraction and comfort of users

The NET800 range uses best in class ergonomic design, including the detailed use of biometric data. The display, touchscreen and keyboard are placed for optimum effect, for both attraction and ease of use.

Input devices use best in class technology, for example the robust keyboard, trackball and touchscreen. Payment interface devices, including card and coin inputs are logically located together.

## Card systems

X2Connect's terminals allow a variety of card schemes. Solutions offered include hybrid magnetic and chip systems.

## Coin Systems

X2Connect's terminals offer a mix of highly proven and secure coin acceptance systems. Escrow systems are offered and coinset download options are available for maximum flexibility.

**The NET800 product range provides the most robust physical configuration available within the industry for hostile conditions, supporting both single and multiple application environments.**

**Product Architecture**

X2Connect's NET800 product range provides the architecture to support the future development of the industry taking into consideration the migration paths of networks and the technological and protocol advancements being introduced continuously. Therefore the NET800 range is specifically designed for: -

- Multi-service Applications and Support
  - Integrated multimedia and user interaction.
  - Can support legacy and cell/packet based applications
  - Offers Quality of Service.
- Future-proof
  - NET800 supports standardised network interfaces (LAN, DSL, IEE802.11, ISDN)
- Intelligent
  - Content and application management.
- Efficient
  - Uses a minimum number of elements to improve capex and opex
  - Extremely reliable, offering best in class central management capabilities
- Evolutionary
  - Provides exciting new and complementary revenue streams for service providers.



**Revenue Generating and Services Features**

- E-commerce applications: transaction revenues:-
  - Mobile content retailing
  - Games
- Custom commercial applications: promote business services
- Secure Internet browsing: pay per session and free access for information services
- Text, Picture and Video Email services
- MMS and SMS mobile phone messaging
- Chargeable and free information services
- Full screen (800 x 600 pixels) advertising
- Capacitive touchscreen interface: intuitive interaction and supporting features such as click to dial
- On-screen banner advertising
- Sponsored content, Point of Sale, Point of Information and specialised applications.
- Local directory services: sponsorship
- Choice of payments accepted: maximum user access
- Customisable user interfaces: for brand awareness and promotion

**Low Cost of Ownership**

- Robust and secure: maximum product up-time: Tough keyboard, tough screen
- Flexible network interfaces: complements network strategies
- Anti-fraud and anti-hacking measures: secure operation
- Proven reliability in the field: confidence in performance
- Sophisticated remote management: for network efficiency
- Remote updates of content and software: low cost updates.



**Physical options**

- Wall-mounted
- Booth Mounted

**Hardware options: -**

1. Handset
2. Telephony Keypad and Display – or optional branding area for point of information sectors
3. Card Reader
4. Video Camera, Microphone & Audio Speakers
5. Coin System (Eight Coin Escrow System)
6. Full QWERTY Keyboard
7. Network Devices: - DSL, IEE802.11, LAN.

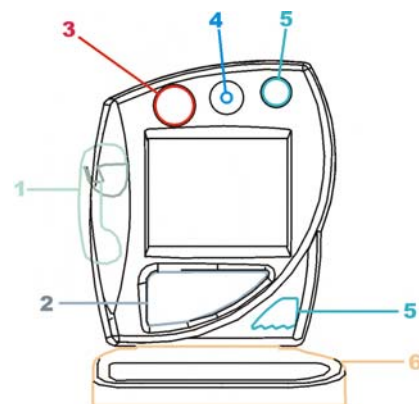

Network Place, Brunel Drive  
Newark  
Nottinghamshire  
NG24 2EG  
United Kingdom

Telephone: +44 (0) 1636 615335  
Fax: +44 (0) 1636 611120  
Email: info@x2connect.com

© X2 Connect Limited 2010. All rights reserved

The information contained herein is the property of X2 Connect Limited and is supplied without liability for errors or omissions. No part may be reproduced or used except as authorised by contract or other written permission.

The copyright and the foregoing restriction on reproduction and use extend to all media in which the information may be embodied.